

# GUITAR AMPLIFIER

# JAZZ CHORUS JC-120

## Owner's Manual



Thank you for purchasing the Roland JC-120 JAZZ CHORUS Guitar Amplifier. To take full advantage of this amplifier, and to ensure years of trouble-free service, please read this Owner's Manual in its entirety.

### Features

---

- 120 watts (rms) of output power; 2 channels of 60 watts each. Channel 2 is equipped with Roland's renowned chorus effect.
- Two input jacks (high-gain and low-gain) accommodate virtually any guitar.
- Both channels contain a Bright switch for greater tonal control.
- A three-spring reverb unit produces a warm, distinctive sound.
- The reinforced cabinet is designed to withstand the rigors of the road while providing characteristic styling.
- Chorus/Vibrato, Reverb and Distortion can all be controlled by footswitches leaving your hands free for playing.
- Channel 2 contains an effects loop circuit that allows you to select either a series or parallel connection. Further, it provides selection of a +4dBm or -20dBm input level to match the level of your effects device.

Before using this unit, carefully read the sections entitled: "IMPORTANT SAFETY INSTRUCTIONS" (p. 2), "USING THE UNIT SAFELY" (p. 3), and "IMPORTANT NOTES" (p. 4). These sections provide important information concerning the proper operation of the unit. Additionally, in order to feel assured that you have gained a good grasp of every feature provided by your new unit, this manual should be read in its entirety. The manual should be saved and kept on hand as a convenient reference.

	<b>CAUTION</b> RISK OF ELECTRIC SHOCK DO NOT OPEN	
<b>ATTENTION:</b> RISQUE DE CHOC ELECTRIQUE NE PAS QUVRIR		
<b>CAUTION:</b> TO REDUCE THE RISK OF ELECTRIC SHOCK, DO NOT REMOVE COVER (OR BACK). NO USER-SERVICEABLE PARTS INSIDE. REFER SERVICING TO QUALIFIED SERVICE PERSONNEL.		



The lightning flash with arrowhead symbol, within an equilateral triangle, is intended to alert the user to the presence of uninsulated "dangerous voltage" within the product's enclosure that may be of sufficient magnitude to constitute a risk of electric shock to persons.



The exclamation point within an equilateral triangle is intended to alert the user to the presence of important operating and maintenance (servicing) instructions in the literature accompanying the product.

INSTRUCTIONS PERTAINING TO A RISK OF FIRE, ELECTRIC SHOCK, OR INJURY TO PERSONS.

## IMPORTANT SAFETY INSTRUCTIONS SAVE THESE INSTRUCTIONS

**WARNING** - When using electric products, basic precautions should always be followed, including the following:

1. Read all the instructions before using the product.
2. Do not use this product near water — for example, near a bathtub, washbowl, kitchen sink, in a wet basement, or near a swimming pool, or the like.
3. This product should be used only with a cart or stand that is recommended by the manufacturer.
4. This product, either alone or in combination with an amplifier and headphones or speakers, may be capable of producing sound levels that could cause permanent hearing loss. Do not operate for a long period of time at a high volume level or at a level that is uncomfortable. If you experience any hearing loss or ringing in the ears, you should consult an audiologist.
5. The product should be located so that its location or position does not interfere with its proper ventilation.
6. The product should be located away from heat sources such as radiators, heat registers, or other products that produce heat.
7. The product should be connected to a power supply only of the type described in the operating instructions or as marked on the product.
8. The power-supply cord of the product should be unplugged from the outlet when left unused for a long period of time.
9. Care should be taken so that objects do not fall and liquids are not spilled into the enclosure through openings.
10. The product should be serviced by qualified service personnel when:
  - A. The power-supply cord or the plug has been damaged; or
  - B. Objects have fallen, or liquid has been spilled onto the product; or
  - C. The product has been exposed to rain; or
  - D. The product does not appear to operate normally or exhibits a marked change in performance; or
  - E. The product has been dropped, or the enclosure damaged.
11. Do not attempt to service the product beyond that described in the user-maintenance instructions. All other servicing should be referred to qualified service personnel.

For the USA

### GROUNDING INSTRUCTIONS

This product must be grounded. If it should malfunction or breakdown, grounding provides a path of least resistance for electric current to reduce the risk of electric shock.

This product is equipped with a cord having an equipment-grounding conductor and a grounding plug. The plug must be plugged into an appropriate outlet that is properly installed and grounded in accordance with all local codes and ordinances.

**DANGER:** Improper connection of the equipment-grounding conductor can result in a risk of electric shock. Check with a qualified electrician or serviceman if you are in doubt as to whether the product is properly grounded. Do not modify the plug provided with the product — if it will not fit the outlet, have a proper outlet installed by a qualified electrician.

For the U.K.

**WARNING:** THIS APPARATUS MUST BE EARTHED

**IMPORTANT:** THE WIRES IN THIS MAINS LEAD ARE COLOURED IN ACCORDANCE WITH THE FOLLOWING CODE.  
GREEN-AND-YELLOW: EARTH, BLUE: NEUTRAL, BROWN: LIVE

As the colours of the wires in the mains lead of this apparatus may not correspond with the coloured markings identifying the terminals in your plug, proceed as follows:

The wire which is coloured GREEN-AND-YELLOW must be connected to the terminal in the plug which is marked by the letter E or by the safety earth symbol  or coloured GREEN or GREEN-AND-YELLOW.

The wire which is coloured BLUE must be connected to the terminal which is marked with the letter N or coloured BLACK.



The wire which is coloured BROWN must be connected to the terminal which is marked with the letter L or coloured RED.

The product which is equipped with a THREE WIRE GROUNDING TYPE LINE PLUG must be grounded.







# USING THE UNIT SAFELY

## INSTRUCTIONS FOR THE PREVENTION OF FIRE, ELECTRIC SHOCK, OR INJURY TO PERSONS

### About WARNING and CAUTION Notices









 <b>WARNING</b>	Used for instructions intended to alert the user to the risk of death or severe injury should the unit be used improperly.
 <b>CAUTION</b>	Used for instructions intended to alert the user to the risk of injury or material damage should the unit be used improperly. * Material damage refers to damage or other adverse effects caused with respect to the home and all its furnishings, as well to domestic animals or pets.

### About the Symbols









	The  symbol alerts the user to important instructions or warnings. The specific meaning of the symbol is determined by the design contained within the triangle. In the case of the symbol at left, it is used for general cautions, warnings, or alerts to danger.
	The  symbol alerts the user to items that must never be carried out (are forbidden). The specific thing that must not be done is indicated by the design contained within the circle. In the case of the symbol at left, it means that the unit must never be disassembled.
	The  symbol alerts the user to things that must be carried out. The specific thing that must be done is indicated by the design contained within the circle. In the case of the symbol at left, it means that the power-cord plug must be unplugged from the outlet.

## ALWAYS OBSERVE THE FOLLOWING

### WARNING

- Before using this unit, make sure to read the instructions below, and the Owner's Manual. 
- Do not open or perform any internal modifications on the unit. 
- Make sure you always have the unit placed so it is level and sure to remain stable. Never place it on stands that could wobble, or on inclined surfaces. 
- Avoid damaging the power cord. Do not bend it excessively, step on it, place heavy objects on it, etc. A damaged cord can easily become a shock or fire hazard. Never use a power cord after it has been damaged. 
- In households with small children, an adult should provide supervision until the child is capable of following all the rules essential for the safe operation of the unit. 
- Protect the unit from strong impact. (Do not drop it!) 
- Do not force the unit's power-supply cord to share an outlet with an unreasonable number of other devices. Be especially careful when using extension cords—the total power used by all devices you have connected to the extension cord's outlet must never exceed the power rating (watts/amperes) for the extension cord. Excessive loads can cause the insulation on the cord to heat up and eventually melt through. 
- Before using the unit in a foreign country, consult with your dealer, or qualified Roland service personnel. 

### CAUTION

- Always grasp only the plug on the power-supply cord when plugging into, or unplugging from an outlet. 
- Try to prevent cords and cables from becoming entangled. Also, all cords and cables should be placed so they are out of the reach of children. 
- If the unit could become a hazard if it moves, all caster wheels should be removed once the unit has been placed at the place of installation, or has been loaded onto a vehicle. 
- Never climb on top of, nor place heavy objects on the unit. 
- Never handle the power cord or its plug with wet hands when plugging into, or unplugging from, an outlet. 
- Before moving the unit, disconnect the power plug from the outlet, and pull out all cords from external devices. 
- Before cleaning the unit, turn off the power and unplug the power cord from the outlet (p. 4). 
- Whenever you suspect the possibility of lightning in your area, pull the plug on the power cord out of the outlet. 

---

## IMPORTANT NOTES

---

In addition to the items listed under "IMPORTANT SAFETY INSTRUCTIONS" and "USING THE UNIT SAFELY" on pages 2 and 3, please read and observe the following:

### Power Supply

- Do not use this unit on the same power circuit with any device that will generate line noise (such as an electric motor or variable lighting system).
- Before connecting this unit to other devices, turn off the power to all units. This will help prevent malfunctions and/or damage to speakers or other devices.

### Placement

- Using the unit near power amplifiers (or other equipment containing large power transformers) may induce hum. To alleviate the problem, change the orientation of this unit; or move it farther away from the source of interference.
- This device may interfere with radio and television reception. Do not use this device in the vicinity of such receivers.
- Do not expose the unit to direct sunlight, place it near devices that radiate heat, leave it inside an enclosed vehicle, or otherwise subject it to temperature extremes. Excessive heat can deform or discolor the unit.
- This unit contains powerful magnets. If placed in the vicinity of TVs, it may cause interference (irregularities in color). Should this occur, reposition this unit so it is located at a greater distance from such devices.

### Maintenance

- For everyday cleaning wipe the unit with a soft, dry cloth or one that has been slightly dampened with water. To remove stubborn dirt, use a cloth impregnated with a mild, non-abrasive detergent. Afterwards, be sure to wipe the unit thoroughly with a soft, dry cloth.
- Never use benzene, thinners, alcohol or solvents of any kind, to avoid the possibility of discoloration and/or deformation.

### Additional Precautions

- Use a reasonable amount of care when using the unit's buttons, sliders, or other controls; and when using its jacks and connectors. Rough handling can lead to malfunctions.
- When connecting / disconnecting all cables, grasp the connector itself—never pull on the cable. This way you will avoid causing shorts, or damage to the cable's internal elements.
- A small amount of heat will radiate from the unit during normal operation.
- To avoid disturbing your neighbors, try to keep the unit's volume at reasonable levels (especially when it is late at night).
- When you need to transport the unit, package it in the box (including padding) that it came in, if possible. Otherwise, you will need to use equivalent packaging materials.

# Panel Description

## Front Panel

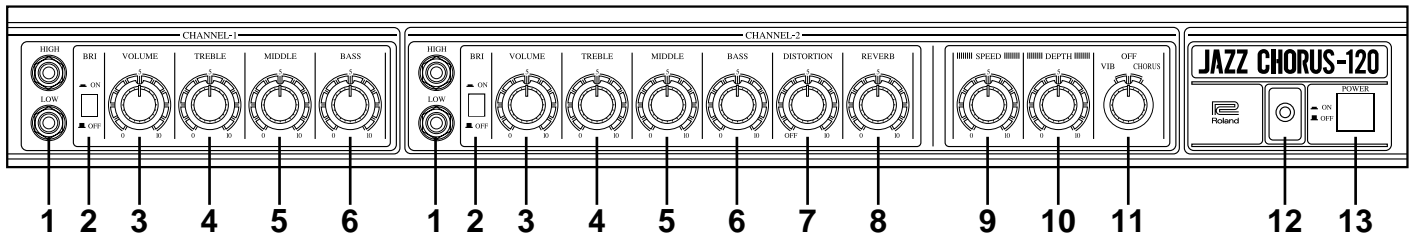

### 1. Input Jacks

Two input jacks are provided. For a guitar with a standard output, use the “HIGH” input. For very high output instruments, use the “LOW” input.

### 2. BRI (Bright) Switch

When this switch is set to ON, a bright, clear sound can be obtained.

### 3. VOLUME Knob

Clockwise rotation will increase the amplifier’s overall volume.

### 4. TREBLE Control Knob

Clockwise rotation will boost the higher frequencies.

### 5. MIDDLE Control Knob

Clockwise rotation will boost the all-important middle frequencies.

### 6. BASS Control Knob

Clockwise rotation will boost the lower frequencies.

### 7. DISTORTION Knob

Clockwise rotation will intensify the distortion effect. “OFF” turns the effect off.

### 8. REVERB Knob

Clockwise rotation will intensify the reverb effect.

### 9. Vibrato SPEED Knob

This knob adjusts the rate (frequency of the sound vibrations) of the vibrato effect. Clockwise rotation increases the vibrato speed.

### 10. Vibrato DEPTH Knob

This knob adjusts the depth of the vibrato effect. Clockwise rotation deepens the vibrato effect.

### 11. VIB/OFF/CHORUS Switch

This knob selects the Chorus or Vibrato effect. When it is set to the “OFF” position neither effect will be obtained.

\* Neither the speed nor depth of the Chorus effect can be changed.

### 12. Pilot Lamp

This will light when the amplifier is switched on.

### 13. POWER Switch

This switch turns the amplifier on and off.

\* To prevent malfunction and/or damage to speakers or other devices, always turn down the volume, and turn off the power on all devices before making any connections. You may hear a “DC thump” when switching the amplifier on or off but this is normal.

\* This unit is equipped with a protection circuit. A brief interval (a few seconds) after power up is required before the unit will operate normally.

## Rear Panel

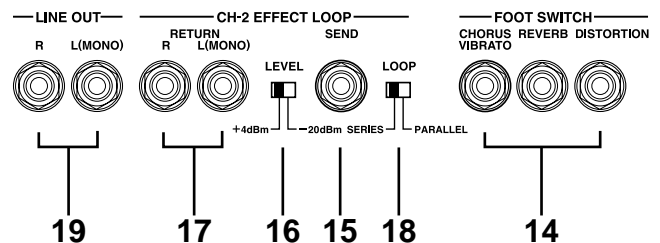

### 14. FOOTSWITCH Jacks

With the proper footswitch connected to the appropriate jack, you can obtain on/off control of Chorus/Vibrato, Reverb and/or Distortion.

\* Even when a footswitch is turned on, no effect will be obtained if knobs 7 and 11 are in the “OFF” positions.

### 15. CH-2 EFFECT LOOP SEND Jack

This is the jack from which the dry (unprocessed) signal is sent to the effects device.

## 16. CH-2 EFFECT LOOP LEVEL Switch

This switch selects the input/output level for the Channel 2 effects loop. Change the switch position to accommodate the effects device you are using. When the connected unit's input/output level is high, set the switch to "+4dBm," and when that level is low, set the switch to "-20dBm."

## 17. CH-2 EFFECT LOOP RETURN Jacks

These are input jacks for the return signal from your effects device. Stereo connections (L/R) are possible. To use the unit in mono, use the L(MONO) jack.

*\* When using this unit in mono, the return sound will not be output through the speakers even if you input the return sound to the RETURN R jack. That is, when the L(MONO) jack is not used, only direct sounds will be output (regardless of the LOOP switch setting).*

*\* Before you make connections to the RETURN jack(s), be sure to switch the units off.*

## 18. CH-2 EFFECT LOOP Switch

This switch selects either the series or parallel connection for the Effects Loop circuit.

When PARALLEL is selected, external effects sounds and direct sounds (unprocessed sounds) will be mixed. When SERIES is selected, external effects sounds will not be mixed with direct sounds.

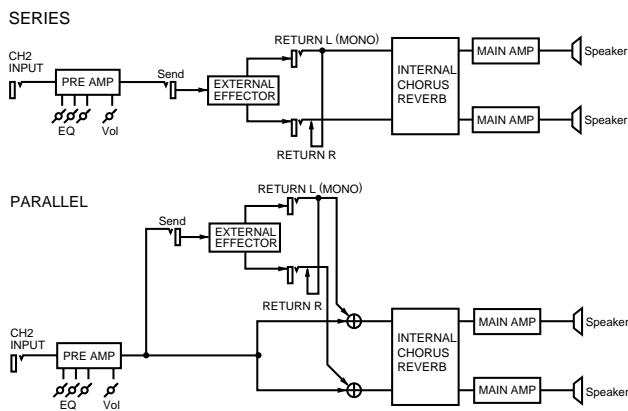

## 19. LINE OUT Jacks

Use these jacks to connect the JC-120 to another guitar amplifier or mixer, or to a tape deck for recording. A stereo pair (L/R) is provided, but mono connections are also possible (use the L(MONO) jack).

## Switching On Power

*\* Turn on power to your various devices in the order specified. By turning on devices in the wrong order, you risk causing malfunction and/or damage to speakers and other devices.*

1. Switch on the power on all devices EXCEPT the device(s) connected to the LINE OUT jacks (19).
2. Turn on the JC-120's power.
3. Finally, switch on the power on any devices connected to the LINE OUT jacks.

## Attaching/Removing Caster Wheels

The caster wheels were not attached at the factory. To attach or remove them, do as shown in the illustration.

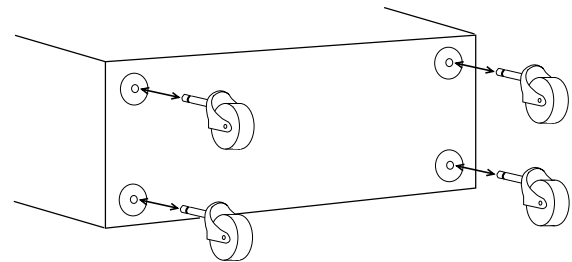

# SPECIFICATIONS

<b>Rated Power output</b>	120W (60W+60W) / 8Ω + 8Ω
<b>Speakers</b>	30cm (12inches) + 30cm (12inches)
<b>Power Supply</b>	AC 117V, AC 230V or AC 240V
<b>Power Consumption</b>	110W (117V, 230V, 230VE, 240VA)
<b>Nominal Input Level</b>	-30dBm / 680kΩ 0dBm=0.775V
<b>Connectors</b>	CH-1 Input Jacks (HIGH, LOW) CH-2 Input Jacks (HIGH, LOW), FOOTSWITCH Jacks (CHORUS/VIBRATO, REVERB, and DISTORTION) CH-2 EFFECT LOOP SEND Jack CH-2 EFFECT LOOP RETURN Jacks (L/(MONO), R) LINE OUT Jacks (L/(MONO), R)
<b>Controls</b>	CH-1: BRI (Bright) Switch, VOLUME Knob, TREBLE Control Knob, MIDDLE Control Knob, BASS Control Knob CH-2: BRI (Bright) Switch, VOLUME Knob, TREBLE Control Knob, MIDDLE Control Knob, BASS Control Knob, DISTORTION Knob, REVERB Knob, Vibrato SPEED Knob, Vibrato DEPTH Knob, VIB/OFF/CHORUS Switch POWER Switch, CH-2 EFFECT LOOP Switch, CH-2 EFFECT LOOP LEVEL Switch
<b>Dimensions</b>	760(W) x 280(D) x 622(H) mm (includes casters) 29-15/16 (W) x 11-1/16 (D) x 24-1/2 (H) inches
<b>Weight</b>	31.2 kg / 68 lbs 13 oz
<b>Accessories</b>	Owner's Manual
<b>Options</b>	Footswitch : FS-5L (BOSS)

\* In the interest of product improvement, the specifications and/or appearance of this unit are subject to change without prior notice.



This product complies with the requirements of European Directive 89/336/EEC.

For Europe

## FEDERAL COMMUNICATIONS COMMISSION RADIO FREQUENCY INTERFERENCE STATEMENT

This equipment has been tested and found to comply with the limits for a Class B digital device, pursuant to Part 15 of the FCC Rules. These limits are designed to provide reasonable protection against harmful interference in a residential installation. This equipment generates, uses, and can radiate radio frequency energy and, if not installed and used in accordance with the instructions, may cause harmful interference to radio communications. However, there is no guarantee that interference will not occur in a particular installation. If this equipment does cause harmful interference to radio or television reception, which can be determined by turning the equipment off and on, the user is encouraged to try to correct the interference by one or more of the following measures:

- Reorient or relocate the receiving antenna.
- Increase the separation between the equipment and receiver.
- Connect the equipment into an outlet on a circuit different from that to which the receiver is connected.
- Consult the dealer or an experienced radio/TV technician for help.

Unauthorized changes or modification to this system can void the users authority to operate this equipment. This equipment requires shielded interface cables in order to meet FCC class B Limit.

For the USA

### CLASS B

### NOTICE

This digital apparatus does not exceed the Class B limits for radio noise emissions set out in the Radio Interference Regulations of the Canadian Department of Communications.

### CLASSE B

### AVIS

Cet appareil numérique ne dépasse pas les limites de la classe B au niveau des émissions de bruits radioélectriques fixés dans le Règlement des signaux parasites par le ministère canadien des Communications.

For Canada

# Information

When you need repair service, call your nearest Roland Service Center or authorized Roland distributor in your country as shown below.

## ARGENTINA

**Instrumentos Musicales S.A.**  
Florida 638  
(1005) Buenos Aires  
ARGENTINA  
TEL: (01) 394 4029

## BRAZIL

**Roland Brasil Ltda.**  
R. Coronel Octaviano da Silveira  
203 05522-010  
Sao Paulo BRAZIL  
TEL: (011) 843 9377

## CANADA

**Roland Canada Music Ltd.**  
**(Head Office)**  
5480 Parkwood Way Richmond  
B. C., V6V 2M4 CANADA  
TEL: (0604) 270 6626

**Roland Canada Music Ltd.**  
**(Toronto Office)**

Unit 2, 109 Woodbine Downs  
Blvd, Etobicoke, ON  
M9W 6Y1 CANADA  
TEL: (0416) 213 9707

## MEXICO

**Casa Veerkamp, s.a. de c.v.**  
Av. Toluca No. 323 Col. Olivar de  
los Padres 01780 Mexico D.F.  
MEXICO  
TEL: (525) 668 04 80

**La Casa Wagner de  
Guadalajara s.a. de c.v.**  
Av. Corona No. 202 S.J.  
Guadalajara, Jalisco Mexico  
C.P.44100 MEXICO  
TEL: (03) 613 1414

## PANAMA

**Productos Superiores, S.A.**  
Apartado 655 - Panama 1  
REP. DE PANAMA  
TEL: 26 3322

## U. S. A.

**Roland Corporation U.S.**  
7200 Dominion Circle  
Los Angeles, CA. 90040-3696,  
U. S. A.  
TEL: (0213) 685 5141

## VENEZUELA

**Musicland Digital C.A.**  
Av. Francisco de Miranda,  
Centro Parque de Cristal, Nivel  
C2 Local 20 Caracas  
VENEZUELA  
TEL: (02) 285 9218

## AUSTRALIA

**Roland Corporation  
Australia Pty. Ltd.**  
38 Campbell Avenue  
Dee Why West. NSW 2099  
AUSTRALIA  
TEL: (02) 982 8266

## NEW ZEALAND

**Roland Corporation (NZ) Ltd.**  
97 Mt. Eden Road, Mt. Eden,  
Auckland 3, NEW ZEALAND  
TEL: (09) 3098 715

## CHINA

**Beijing Xinghai Musical  
Instruments Co., Ltd.**  
2 Huangmunchang Chao Yang  
District, Beijing, CHINA  
TEL: (010) 6774 7491

## HONG KONG

**Tom Lee Music Co., Ltd.**  
**Service Division**  
22-32 Pun Shan Street, Tsuen  
Wan, New Territories,  
HONG KONG  
TEL: 2415 0911

## INDONESIA

**PT Galestra Inti**  
Kompleks Perkantoran  
Duta Merlin Blok E No.6—7  
Jl. Gajah Mada No.3—5,  
Jakarta 10130,  
INDONESIA  
TEL: (021) 6335416

## KOREA

**Cosmos Corporation  
Service Station**  
261 2nd Floor Nak-Won Arcade  
Jong-Ro ku, Seoul, KOREA  
TEL: (02) 742 8844

## MALAYSIA

**Bentley Music SDN BHD**  
No.142, Jalan Bukit Bintang 55100  
Kuala Lumpur, MALAYSIA  
TEL: (03) 2443333

## PHILIPPINES

**G.A. Yupangco & Co. Inc.**  
339 Gil J. Puyat Avenue  
Makati, Metro Manila 1200,  
PHILIPPINES  
TEL: (02) 899 9801

## SINGAPORE

**Swee Lee Company**  
BLOCK 231, Bain Street #03-23  
Bras Basah Complex,  
SINGAPORE 0718  
TEL: 3367886

## CRISTOFORI MUSIC PTE LTD

335, Joo Chiat Road SINGAPORE  
1542  
TEL: 3450435

## TAIWAN

**ROLAND TAIWAN  
ENTERPRISE CO., LTD.**  
Room 5, 9fl. No. 112 Chung Shan  
N.Road Sec.2, Taipei, TAIWAN,  
R.O.C.  
TEL: (02) 561 3339

## THAILAND

**Theera Music Co., Ltd.**  
330 Veng Nakorn Kasem, Soi 2,  
Bangkok 10100, THAILAND  
TEL: (02) 2248821

## BAHRAIN

**Moon Stores**  
Bad Al Bahrain Road,  
P.O.Box 20077  
State of BAHRAIN  
TEL: 211 005

## IRAN

**TARADIS**  
Mir Emad Ave. No. 15, 10th street  
P. O. Box 15875/4171 Teheran,  
IRAN  
TEL: (021) 875 6524

## ISRAEL

**Halilit P. Greenspoon &  
Sons Ltd.**  
8 Retzif Ha'aliya Hashnya St.  
Tel-Aviv-Yafo ISRAEL  
TEL: (03) 6823666

## JORDAN

**AMMAN Trading Agency**  
Prince Mohammed St. P. O. Box  
825 Amman 11118 JORDAN  
TEL: (06) 641200

## KUWAIT

**Easa Husain Al-Yousifi**  
P.O. Box 126 Safat 13002  
KUWAIT  
TEL: 5719499

## LEBANON

**A. Chahine & Fils**  
P.O. Box 16-5857 Gergi Zeidan St.  
Chahine Building, Achrafieh  
Beirut, LEBANON  
TEL: (01) 335799

## OMAN

**OHI Electronics & Trading  
Co. LLC**  
P. O. Box 889 Muscat  
Sultanate of OMAN  
TEL: 706 010

## QATAR

**Badie Studio & Stores**  
P.O.Box 62,  
DOHA QATAR  
TEL: 423554

## SAUDI ARABIA

**Abdul Latif S. Al-Ghamdi  
Trading Establishment**  
Middle East Commercial Center  
Al-Khobar Dharan Highway  
W/hamood st.  
P. O. Box 3631 Al-Khobar  
31952 SAUDIARABIA  
TEL: (03) 898 2332

## SYRIA

**Technical Light & Sound  
Center**  
Khaled Ebn Al Walid St.  
P.O.Box 13520  
Damascus - SYRIA  
TEL: (011) 2235 384

## TURKEY

**Barkat Sanayi ve Ticaret**  
Sirasevlier Cad. Guney Ishani No.  
86/6 Taksim, Istanbul TURKEY  
TEL: (0212) 2499324

## U. A. E.

**Zak Electronics & Musical  
Instruments Co.**  
Zabeel Road, Al Sherooq Bldg.,  
No. 14, Grand Floor DUBAI  
U.A.E.  
P.O. Box 8050DUBAI, U.A.E  
TEL: (04) 360715

## EGYPT

**Al Fanny Trading Office**  
9, Ebn Hagar Ai Askalany Street,  
Ard El Golf, Heliopolis, Cairo,  
11341 EGYPT  
TEL: (02) 4171828  
(02) 4185531

## KENYA

**Musik Land Limited**  
P.O Box 12183 Moi Avenue  
Nairobi Republic of KENYA  
TEL: (2) 338 346

## MAURITIOUS

**Philanne Music Center**  
4th, Floor Noll, Happy World  
House Sir William Newton Street  
Port Luis MAURITIOUS  
TEL: 242 2986

## REUNION

**FO - YAM Marcel**  
25 Rue Jules MermanZL  
Chaudron - BP79 97491  
Ste Clotilde REUNION  
TEL: 28 29 16

## SOUTH AFRICA

**That Other Music Shop  
(PTY) Ltd.**  
11 Melle Street (Cnr Melle and  
Juta Street)  
Braamfontein 2001  
Republic of SOUTH AFRICA  
TEL: (011) 403 4105

## Paul Bothner (PTY) Ltd.

17 Werdmuller Centre Claremont  
7700  
Republic of SOUTH AFRICA  
TEL: (021) 64 4030

## AUSTRIA

**E. Dematte & Co.**  
Neu-Rum Siemens-Strasse 4  
A-6040 Innsbruck P.O.Box 83  
AUSTRIA  
TEL: (0512) 26 44 260

## BELGIUM/HOLLAND/ LUXEMBOURG

**Roland Benelux N. V.**  
Houtstraat 1 B-2260 Oevel-  
Westerlo BELGIUM  
TEL: (014) 575811

## BELORUSSIA TUSHE

UL. Rabbkorovskaya 17  
220001 MINSK  
TEL: (0172) 764-911

## CYPRUS

**Radex Sound Equipment Ltd.**  
17 Diagorou St., P.O.Box 2046,  
Nicosia CYPRUS  
TEL: (02) 453 426  
(02) 466 423

## DENMARK

**Roland Scandinavia A/S**  
Langebrogade 6 Post Box 1937  
DK-1023 Copenhagen K.  
DENMARK  
TEL: 32 95 3111

## FRANCE

**MUSIKENGRO**  
Zac de Folliouses 01706  
Les Echets Miribel FRANCE  
TEL: 472 26 2700

## FINLAND

**Roland Scandinavia As,  
Filial Finland**  
Lauttasaarentie 54 B  
Fin-00201 Helsinki, FINLAND  
P. O. Box No. 109  
TEL: (0) 682 4020

## GERMANY

**Roland Elektronische  
Musikinstrumente  
Handelsgesellschaft mbH.**  
Oststrasse 96, 22844 Norderstedt,  
GERMANY  
TEL: (040) 52 60090

## GREECE

**V. Dimitriadis & Co. Ltd.**  
20, Alexandras St. & Bouboulinas  
54 St. 106 82 Athens, GREECE  
TEL: (01) 8232415

## HUNGARY

**Intermusica Ltd.**  
Warehouse Area 'DEPO' Pf.83  
H-2046 Torokbalint, HUNGARY  
TEL: (23) 338 041

## IRELAND

**The Dublin Service Centre  
Audio Maintenance Limited**  
11 Brunswick Place Dublin 2  
Republic of IRELAND  
TEL: (01) 677322

## ITALY

**Roland Italy S. p. A.**  
Viale delle Industrie, 8  
20020 Arese Milano, ITALY  
TEL: (02) 93581311

## NORWAY

**Roland Scandinavia Avd.  
Kontor Norge**  
Lilleakerveien 2 Postboks 95  
Lilleaker N-0216 Oslo  
NORWAY  
TEL: 273 0074

## POLAND

**P. P. H. Brzostowicz Marian**  
UL. Blokowa 32, 03624 Warszawa  
POLAND  
TEL: (022) 679 44 19

## PORTUGAL

**Caius - Tecnologias Audio e  
Musica , Lda.**  
Rue de Catarina 131  
4000 Porto, PORTUGAL  
TEL: (02) 38 4456

## RUSSIA

**PETROSHOP Ltd.**  
11 Sayanskaya Street Moscow  
11531, RUSSIA  
TEL: 095 307 4892

**Slami Music Company**  
Sadojava-Triumfalnaja st., 16  
103006 Moscow, RUSSIA  
TEL: 095 209 2193

## SPAIN

**Roland Electronics  
de España, S. A.**  
Calle Bolivia 239 08020 Barcelona,  
SPAIN  
TEL: (93) 308 1000

## SWEDEN

**Roland Scandinavia A/S**  
Danvik Center 28 A, 2 tr.  
S-131 30 Nacka SWEDEN  
TEL: (08) 702 0020

## SWITZERLAND

**Roland (Switzerland) AG  
Musitronic AG**  
Gerberstrasse 5, CH-4410 Liestal,  
SWITZERLAND  
TEL: (061) 921 1615

## UKRAINE

**TIC-TAC**  
Mira Str. 19/108  
P.O.Box 180  
295400 Munkachevo, UKRAINE  
TEL: (03131) 414-40

## UNITED KINGDOM

**Roland (U.K.) Ltd., Swansea  
Office**  
Atlantic Close, Swansea  
Enterprise Park SWANSEA  
West Glamorgan SA7 9FJ,  
UNITED KINGDOM  
TEL: (01792) 702701

As of April, 18, 1997